

Turntable TTC500,

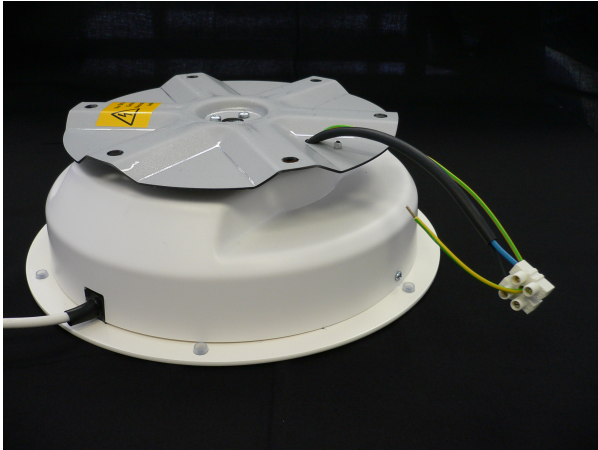

Its massive ground plate can be bold on the ground. The axis led in 3 ball bearings is bending resistant and allows high pressure. It is also appropriate for indoor use in wall or ceiling mounted position. The small radial tolerance causes a very precise rotation.

The silent movement allows application in quiet environment.

Special features:

- Housing in white plastic
- Metal ground plate, white coated
- Very silent
- Maintenance free
- Safety clutch
- Turntable also applicable wall or ceiling mounted (with reduced load of 25 kg).
- Weight without collecting ring 3.9 kg
- Input power drive 6 W (further data on enquiry)

The turntable TTC500 is applicable for 50 kg (110 lbs) centric load.

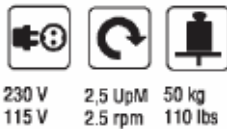
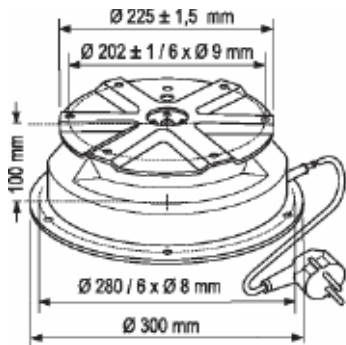

Turntable TTC500

Turntable, available in the following standard versions:

Load horizontal position:

110 lbs

Housing: white plastic

Speed: 2.5 rpm

Turn plate: metal Ø 225 mm

Connection: Schuko / UK / US

Rotating direction: right (cw)

(For other versions, please send us your enquiry)

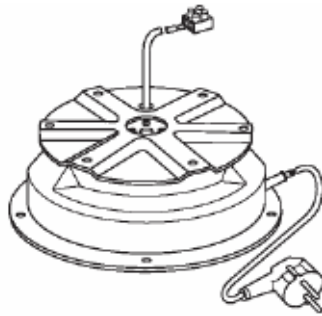
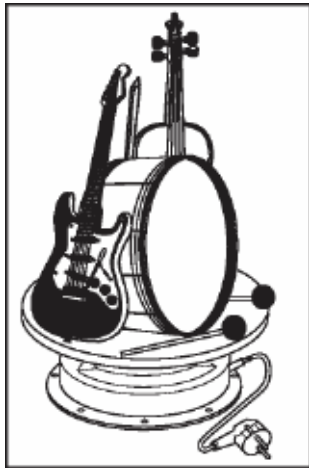

Turntable TTC500

Turntable, available in the following standard versions:

Load horizontal position:

110 lbs

Housing: white plastic

Speed: 2.5 rpm

Turn plate: metal Ø 225 mm

Collecting ring (rotating power supply up to 4 A)

Connection: Schuko / UK / US

Rotating direction: right (cw)

(For other versions, please send us your enquiry)

Technical information:

For vertical mounting (i.e. on the wall) max. 25 kg (55 lbs) load. Absolutely centric load is required. All turntables are available as 110 V version.

The rotation speed in the 60 Hertz mains (US version) is approx. 20% higher than in the 50 Hertz mains. Higher rotation speed can reduce the maximum load.

The above mentioned data may differ from the real situation.

Technical specifications are subject to change without notice

