

## SPECIFICATIONS

### SYSTEM SIZES

Boxed size

Post: 1040 [l] x 115 [w] x 115 [d]mm

Base: 375 [l] x 360 [w] x 45 [d]mm

Assembled size

1000 [h] x 350 [diameter]mm

### BOXED WEIGHTS

Post: 2.5kg

Base: 15.5kg

## COMPONENT LIST

1 x Post assembly  
[including washer and nut]

1 x Polished base cover

1 x Cast base

8 x Blanking Bungs

## CAFÉ BARRIER POST ASSEMBLY INSTRUCTIONS

A

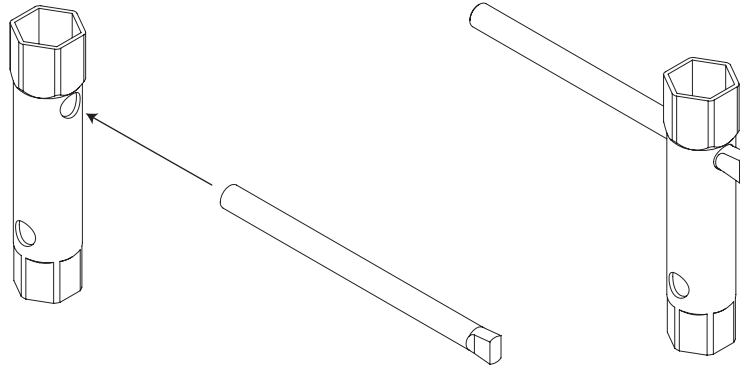

B

