

Cable instructions

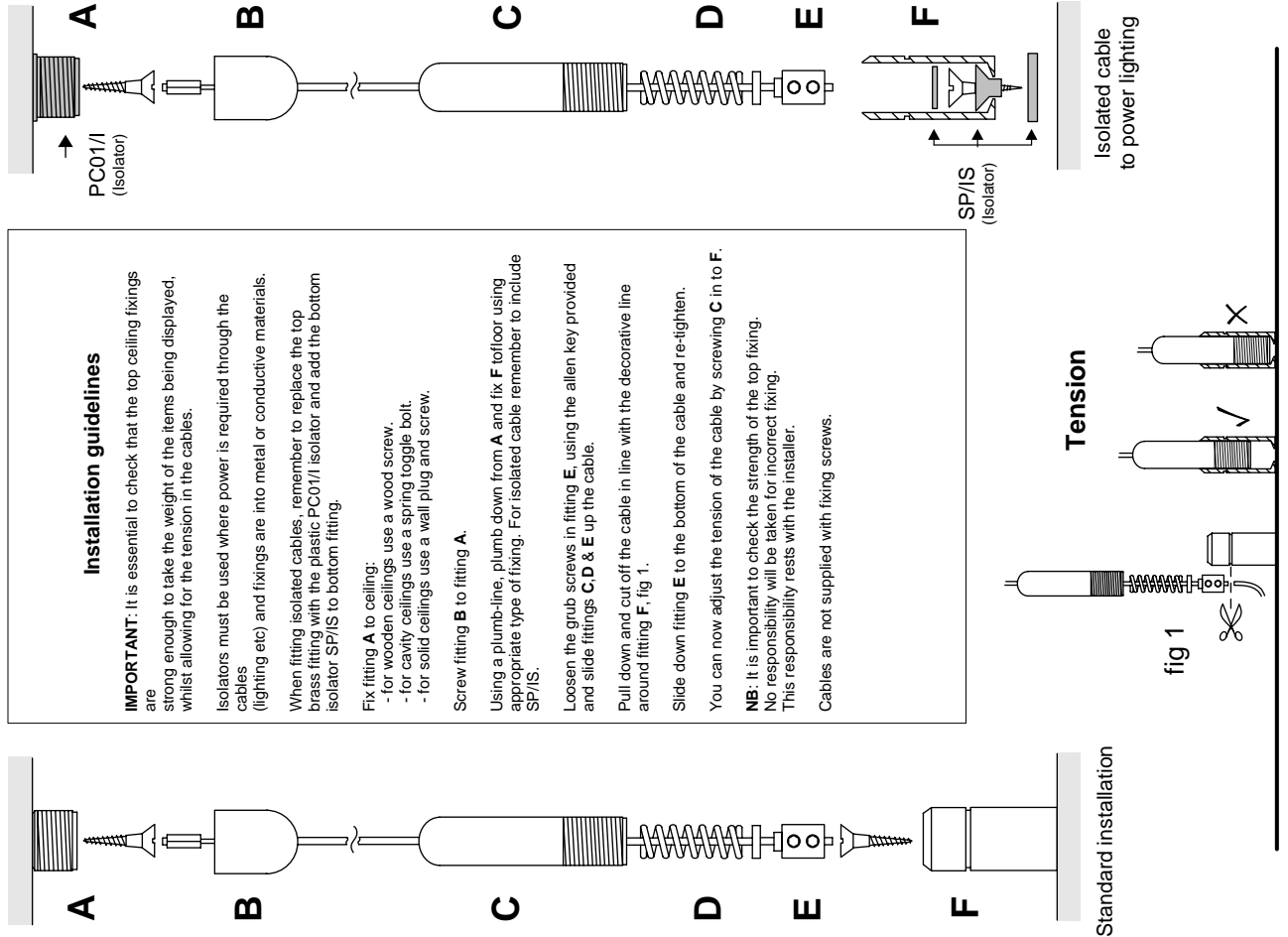

Installation guidelines

IMPORTANT: It is essential to check that the top ceiling fixings are strong enough to take the weight of the items being displayed, whilst allowing for the tension in the cables.

Isolators must be used where power is required through the cables (lighting etc) and fixings are into metal or conductive materials. When fitting isolated cables, remember to replace the top brass fitting with the plastic PC01/I isolator and add the bottom isolator SP/IS to bottom fitting.

Fix fitting A to ceiling:
 - for wooden ceilings use a wood screw.
 - for cavity ceilings use a spring toggle bolt.
 - for solid ceilings use a wall plug and screw.

Screw fitting B to fitting A.

Using a plumb-line, plumb down from A and fix F to floor using appropriate type of fixing. For isolated cable remember to include SP/IS.

Loosen the grub screws in fitting E, using the allen key provided and slide fittings C, D & E up the cable.

Pull down and cut off the cable in line with the decorative line around fitting F, fig 1.

Slide down fitting E to the bottom of the cable and re-tighten.

You can now adjust the tension of the cable by screwing C in to F.

NB: It is important to check the strength of the top fixing. No responsibility will be taken for incorrect fixing. This responsibility rests with the installer.

Cables are not supplied with fixing screws.

Tension

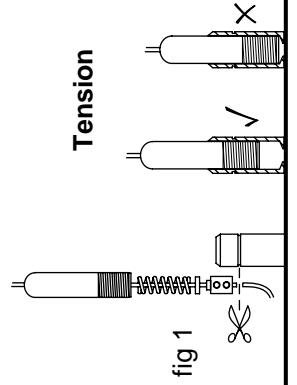
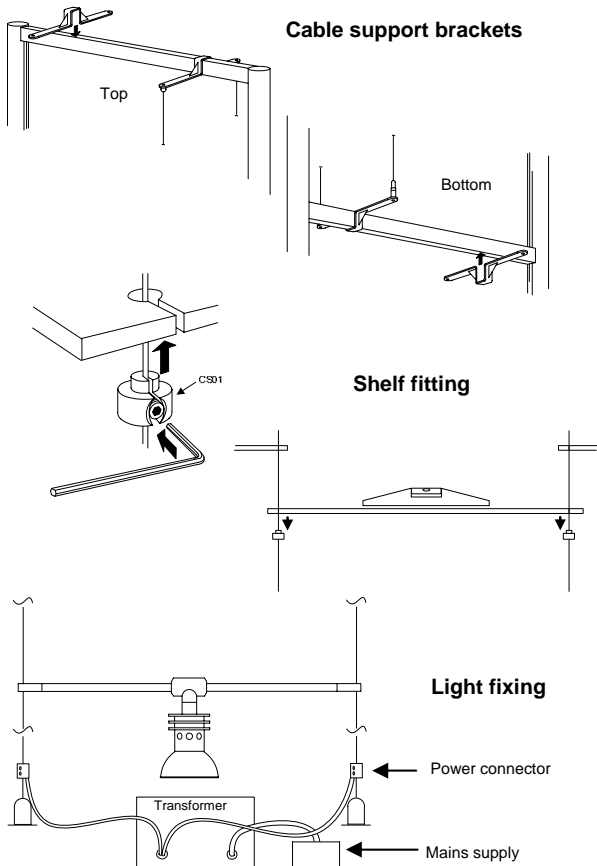

fig 1

Cable support brackets



OPTIONAL FIXINGS

