

Turntable TTC250



The turntable TTC 250 for 25 kg (55 lbs) centric load has a turn plate with large diameter, fixed hollow shaft in the centre and collecting ring option. It provides a wide range of applications. It is appropriate for fix installed lighting on a tube in different lengths. Power supply, lamp holders or devices for fluorescent lamps can be provided standard (i.e. for light cubes). The rotating power supply allows further possibilities. The TTC 250 is also the basic element of the 3level-turntable.

Special features

- Housing in white plastic
- Metal ground plate
- Low noise
- Maintenance free
- Safety clutch
- Optional tube assembled with lampholder
- Optional with collecting ring
- Optional with multi motive turntable
- Optional with rotation tube
- Rotation direction and speed on enquiry
- Weight without tube and collecting ring 2,4 kg
- Input power 4 W (further data on enquiry)

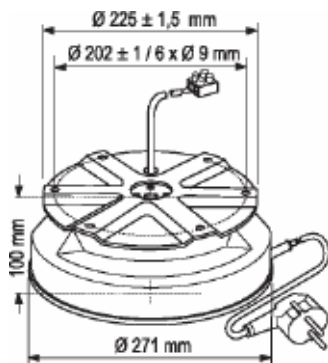

230 V	2,5 UpM	25 kg
115 V	2.5 rpm	55 lbs

Turntable 250

Turntable, available in the following standard versions:

Load horizontal position:
55 lbs

Housing: white plastic
Speed: 2.5 rpm

Turn plate:
metal Ø 225 mm
Optional with collecting ring
(rotating power supply up to 4 A)

Connection: Schuko / UK / US

Rotating direction: right (cw)
(For other versions, please send us your enquiry)